

Shallow Water H₂S Probe

Amperometry

Submarine connector and analog output



Applications

- Monitoring and protection of wastewater networks
- Control of H₂S reagent injections
- Industrial process control
- Aquaculture tanks monitoring
- Control of winemaking processes

Advantages

- Measurement without sampling directly in the field
- No interference with turbidity or colors
- Immersion depth max. 100 meters
- Analog output signal without external controller
- Submarine connector

Support probe and H₂S micro sensor

The H₂S probe has been developed for in situ measurement of the evolution of dissolved hydrogen sulfide concentrations in natural, industrial water and wastewater.

Mounted on multi-parameter systems such as CTD probes, this sensor is composed of a sealed connector, the probe housing incorporate an electronic signal transformation board and a micro sensor H₂S installed in a peak.

Measurement by amperometry allows precise and fast measurements, approximately 2 seconds for 90% of the measurement even for very low concentration with a few micrograms, moreover turbidity and color of the water do not have any influences on measurement.

For the determination of dissolved H₂S concentrations, output signal value must be associated with the sample temperature measurement.

Add the sensor to your installations

This equipment is delivered with the electrode calibration slope, and temperature compensation data with calculation formulas to obtain the H₂S concentration in mg/l. The exchange of the micro-sensor tip is very easy and can be done by users.

The H₂S shallow water probe is also able to integrate an O₂ micro sensor for dissolved oxygen measurements, by replacing the micro H₂S tip.



The dissolved H₂S passes through the gas permeable membrane. It diffuses to the working electrode where an electrochemical oxidation reaction operates. The current generated, proportional to the hydrogen sulphide concentration, is measured by the probe.

This current of 0 to 400 pico-amperes is then converted by the electronic card of the probe into an analog signal from 0 to 5 VDC.

H₂S Probe

Shallow water

Technical specifications

Measuring principle	Amperometric measurement	
Technology	Membrane micro-sensor with redox catalyst	
Temperature compensation	Required - not included	
Electrical polarization	Automatic approx. 15-20 min wait at first use, lower for short stops	
Measurement ranges	Type I	0,05 ... 10 mg/l H ₂ S
	Type II	0,5 ... 50 mg/l H ₂ S
	Type III	0,01 ... 3 mg/l H ₂ S
	Type SL	0,003 ... 1,5 mg/l H ₂ S - Special Low
	Type L	0 ... 100 mg/l H ₂ S - Large
Response time	T 90% 2 seconds	
Measurement accuracy	2 % of the measured value	
H ₂ S consumption	Negligible	
Material	Titanium (housing), silicone (membrane), glass (electrode), epoxy resin	
Dimensions (d x L)	24 mm x 235 mm	
Power supply	9 ... 30 VDC	
Consumption	approx. 0,5 mA with 12 VDC, approx. 0,25 mA with 24 VDC	
Output signal	analog 0 ... 3 VDC	
Connector	SubConn BH-4-MP	
Micro-sensor H ₂ S lifetime	6 months in portable use, 10 in continuous (depends on stress leads by pH variations)	
Interferences on measurement	No interference in salt water up to 40 g/l of salt No interference in presence of: carbon dioxide (up to 25.38 vol.%), Methane (up to 5.78 vol.%), Hydrogen (up to 0.544 vol.%), Ammonia (up to at 1000 ppm (v)), carbon monoxide (up to 92 ppm (v)), CS ₂ (up to 5 vol%), organic solvents (up to 20% vol.), acetic acid (up to at 1 mol / l), dimethyl sulfide	
Maintenance	Distilled water cleaning of the measuring diaphragm after every use	
Temperature of the medium / sample	0 ... + 30 °C (40 °C possible with a specific calibration on request)	
Ambient temperature	0 ... + 40 °C	
Storage temperature	0 ... + 40 °C	
Maximum operating pressure	100 dbar	

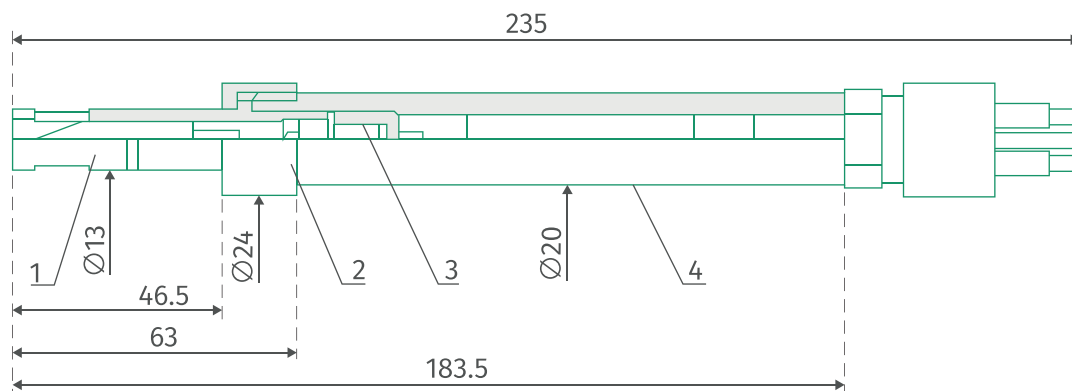
H₂S Sensor